

**AKTOBE RAIL
AND SECTION WORKS**



CATALOGUE

**PRODUCTION
OF RAILS AND SECTIONS**



№1 операторная бурового
Операторская №1

MAIN ABOUT COMPANY

Aktobe Rail and Section Works LLP

 total area
79
ha

 over
900
people

Foundation of Aktobe Rail and Section Works that was to satisfy the demand of state in high-quality rails, was laid in 2013. The construction has truly become nationwide. Specialists almost from all regions of the country as well as near and far abroad were involved in construction of Aktobe Rail and Section Works.

Aktobe Rail and Section Works LLP (hereinafter – ARBZ LLP) is a unique enterprise for production of high-quality differentially heat-strengthened rails and medium sections (flange beams, angles, channels and mine racks), was put into operation on 06 June 2016.

Today, ARBZ LLP is a one-of-a-kind large industrial complex specializing in the production of products of strategic importance such as high-quality differentially heat-strengthened and non-heat-strengthened rails and a wide range of medium sections.

The hallmark of Aktobe Rail and Section Works LLP is long rails of DT350 category. Namely, differentially heat-strengthened rails type R65 category DT350.

In the period from 2016 and to the end of 2023, Aktobe Rail and Section Works LLP reached a historic mark – the plant produced 1 million tons of rails, which is approximately equals to 8 000 km of railway lines.

The strategic goal of the enterprise is production of quality, competitive products for satisfaction of consumer's requests and demands observing the requirements which regulate the activities of iron and steel companies in the field of quality of output products, environment, occupational health and safety.

LIST OF PRODUCTS AND SERVICES



UNIQUE PRODUCTION TECHNOLOGY



Rolling mill of the world-known Siemens-VAI guarantees high-quality and competitiveness of the output that meet the international standard requirements.

Production of heat-strengthened rails of the highest quality and with the length of up to 120 meters which can be used on high-speed and heavy cargo traffic tracks. Extended length allows to reduce a number of weld joints which increases safety and impact on the growth of allowable velocity of the rolling stock.

Rolling process ensures any tight tolerances with regard to accuracy of rail production in accordance with the valid standards.

Differential hardening of rails ensures high hardness, strength of rail head and foot by which increases operational reliability of rails.

High cooling speed during the water-air hardening allows to meet all the technical requirements without additional alloying. Hardening technology allows to produce rails with high operational durability and reliability, increased weldability in accordance with strict requirements of current standards.

Straightness of non-heat-strengthened rails is achieved by cooling on the special Cooling Bed equipped with pre-cambering system.

Rails can withstand the temperature from -60 to +60 degrees Celsius (DT350HH).

RAILS

RAILS - R65

Differentially heat-strengthened	
ДТ370ИК	high wear resistance and contact endurance;
ДТ350BC	for high-speed passenger traffic;
ДТ350CC	for high-speed combined traffic;
ДТ350НН	low-temperature resistance;
ДТ350	for general purposes

Non- heat-strengthened	
H320BC	for high-speed passenger traffic;
H320	high strength for general purpose;
H300	increased strength for general purpose;
H260	conventional strength for general purpose.

RAILS - 60E1, 60E2

With the aim to access to world markets and satisfaction of demands in rails corresponding to the European standard measures were carried out to master and produce new types of rails 60E1 and 60E2. In 2019, a Certificate of Conformance in accordance with the European standard 13674-1:2017 was received. This type of rails is used in the countries of the European Union, the Baltic countries as well as in the countries of the Middle East and North Africa. It is the only company at the territory of CIS able to produce 120 meter rails.

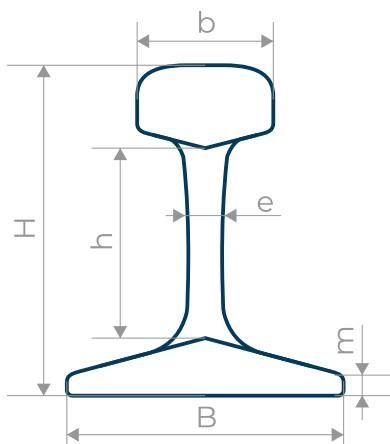

Cross section size	Rail height	Web height	Head width	Foot width	Web thickness	Foot flange height	MM
designation	H	h	b	B	e	m	
RAILS R65	180	105	74,6	150	18	11,2	
RAILS 60E1	172	89,5	72	150	16,5	11,5	

**The only plant in the CIS capable of producing
Rails 120 meters long.**



PROFILED SECTIONS

EQUAL-LEG ANGLE

GOST 8509-93,
GOST 535-2005

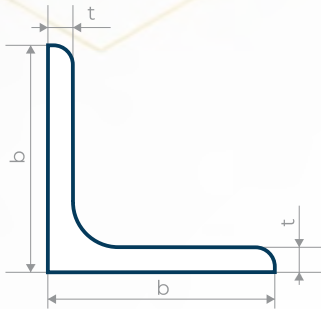

No	b	t	Weight, 1m, kg	No	b	t	Weight, 1m, kg		
10	100	7	10,79	16	160	10	24,67		
		8	12,25			11	27,02		
		10	15,1			12	29,35		
		12	17,9			14	34,2		
		14	20,63			16	38,52		
11	110	7	11,89	18	180	18	43,01		
		8	13,5			20	47,41		
		8	15,46			11	30,47		
12,5	125	9	17,3	18	180	12	33,12		
		10	19,1			12	36,97		
		12	22,68			13	39,92		
		14	140	14	26,2	20	200	14	42,8
				16	29,65			16	48,65
				9	19,41			20	60,08
14	140	10	21,45	20	200	25	74,02		
		12	25,5						

Angle is a profile with a cross-section resembling the letter "L". Angle is used in almost all industries, especially widely used in the construction industry as a rigid reinforcement for reinforcing concrete in monolithic structures of high-rise frame buildings, in heavy-loaded and large-span floors and coverings.

Angle type: steel hot-rolled equal leg

Size: from 100 to 200 mm

Length: from 12 to 24 meters

Application:

- construction (framing, bridges and other structures);
- production of equipment, machine building;
- in the creation of electrical and engineering communications as support elements.

FLANGE BEAM

GOST 8239-89,
GOST 535-2005

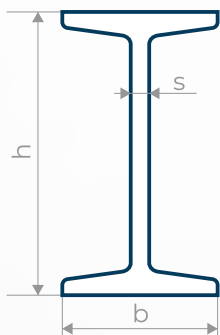

No	h	b	s	Weight, 1m, kg
14	140	73	4,9	13,7
16	160	81	5	15,9
18	180	90	5,1	18,4
20	200	100	5,2	21
22	220	110	5,4	24
24	240	115	5,6	27,3
27	270	125	6	31,5
30	300	135	6,5	36,5

Flange beam is a profile of structural elements that has a cross-section resembling the letter "H" in shape. This product, used in various spheres, is characterized by resistance to high loads, immunity to external influences. The beam of this type is strong, reliable and affordable.

Flange beam type: steel hot-rolled

Size: from 140 to 300 mm

Length: from 12 to 24 meters

Application:

- rail car-, ship-, machinery building;
- construction

PROFILED SECTIONS

CHANNEL

GOST 8240-97,
GOST 535-2005

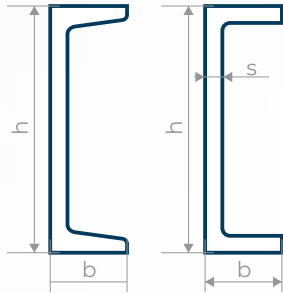

slope of internal faces					parallel faces				
№	h	b	s	Weight, Tm, kg	№	h	b	s	Weight, Tm, kg
16У	160	64	5	14,2	16П	160	64	5	14,2
16аУ	160	68	5	15,3	16аП	160	68	5	15,3
18У	180	70	5	16,3	18П	180	70	5,1	16,3
18аУ	180	74	5	17,4	18аП	180	74	5,1	17,4
20У	200	76	5	18,4	20П	200	76	5,2	18,4
22У	220	82	5	21	22П	220	82	5,4	21
24У	240	90	6	24	24П	240	90	5,6	24
27У	270	95	6	27,7	27П	270	95	6	27,7
30У	300	100	7	31,8	30П	300	100	6,5	31,8

The **channel** is a profile of structural elements having a cross-section resembling the letter "U" and "П" in shape. This product is used for reinforcing reinforced concrete structures, for the production of crane products, electric poles, bridges, oil towers and other large-scale structures. The wide range of use is due to the high level of strength and stability with a relatively small weight of the product.

Channel type: steel hot-rolled with slope of internal faces "U" and parallel faces "П".

Size: from 160 to 300 mm

Length: from 12 to 24 meters

Application:

- construction of support structures, boom cranes;
- car, ship and mechanical engineering;
- construction of floors (roofing and inter-floor), frames.

СВП ШАХТНАЯ СТОЙКА

GOST 18662-83,
GOST 535-2005

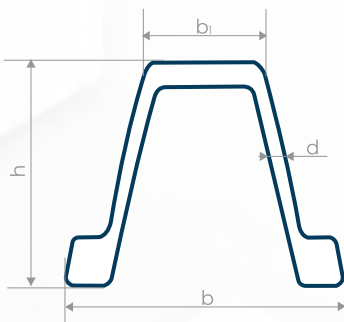

№	Size				Cross-section area	Linear density
	h	b	b	d		
22	110	145,5	60	6,2	27,91	21,9
27	123	149,5	59,5	7,1	34,37	27

Mine racks SVP (special interchangeable profile) - one of the types of hot-rolled steel. They are widely used in the mining industry as elements of circular, trapezoidal and arch-shaped pliable supports in the construction of interfaces of iron ore and coal mines. Supports used by mining industrial enterprises require strength and are able to withstand the load of materials. Mines handle rock deposits at depths using supports weighing at least 22-33 kg per linear meter of metal product.

Production: Production process of special profiles is performed according to the GOST norms which include such technical specifications as bending till parallel sides, weldability, percentage elongation, yield strength, ultimate resistance.





DYNAMICS OF METAL PRODUCT OUTPUT AT ARBZ

In thousand tons

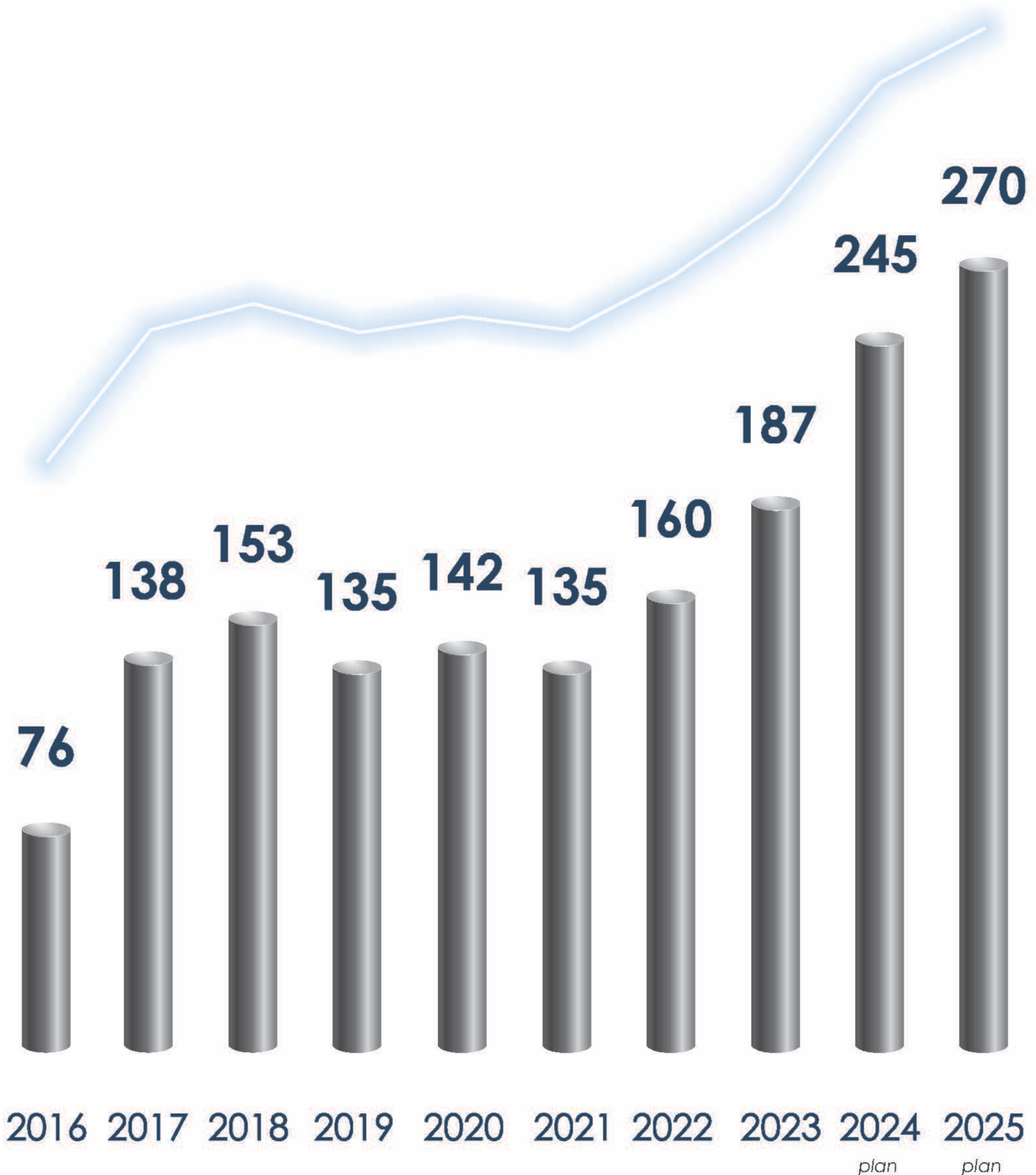

GEOGRAPHY OF SUPPLIES

Currently products of ARBZ LLP are successfully used in construction of upper structures railway tracks by railway administrations and industrial companies. Apart from the internal market ARBZ LLP products are in a high demand in Russia, Uzbekistan, Belarus, Kyrgyzstan, Ukraine, Georgia, Turkmenistan, Azerbaijan, Latvia, Estonia and other countries.

Rails of ARBZ LLP are used in construction of the largest infrastructural project on the territory of the Republic of Kazakhstan – construction of the second railway tracks on Dostyk-Moiynty section. The object is implemented within the framework of National Project “Strong Regions – the Driver of Country's Development” and plays an important economic role in the development of transit and transporting potential of the country. The construction was launched in November, 2022. Total length is 836 kilometers.



CENTRAL PLANT LABORATORY



Aktobe Rails and Section Works LLP has its own laboratory- Central Plant Laboratory (CPL).

CPL conducts tests and analysis of metals according to following indicators:

- chemical composition analysis;
- mass fraction of gases;
- depth of decarburized layer;
- micro and macro structure;
- physical and mechanical properties;
- ultrasonic testing;

CPL is accredited in the accreditation system of the Republic of Kazakhstan for compliance with the requirements of GOST ISO/IEC 17025-2009 "General requirements and competence of testing and calibration laboratories"

CPL is included in the unified register of testing laboratories of the Customs Union on technical regulations.

CPL has received the right to apply the ILAC MRA laboratory combined mark, which ensures international recognition of test results in 75 European countries of this association.

METROLOGY LABORATORY

Metrology laboratory is accredited for compliance with requirements of GOST ISO/IEC 17025-2019 "General requirements for the competence of testing and calibration laboratories.

Metrology laboratory is equipped with modern reference equipment, such as:

- Mitutoyo Crysta-Plus M7106, coordinating and measuring machine, which allows for the verification and calibration of control patterns of geometric dimensions of a product profile.
- "black body" temperature calibrators, according to which verification and calibration of all pyrometers of the rails and section shop is carried out;
- Keller pressure calibrators and a reference digital pressure gauge DM, which are used for verification and calibration of pressure measuring instruments.

The competence of the metrology laboratory is confirmed by accreditation certificates for the right to verify and calibrate measuring instruments and by satisfactory results of the qualification check of the interlaboratory comparisons provider.

The staff of the metrology laboratory annually improves their qualifications on various topics of metrological support and is certified as verifiers of measuring instruments.

CERTIFICATES

Integrated Management System has been implemented, and is acted by the Enterprise.

Implementation and continuous enhancement of management system resulted in increase of efficiency of manufacturing processes and competitiveness of the Enterprise's products.

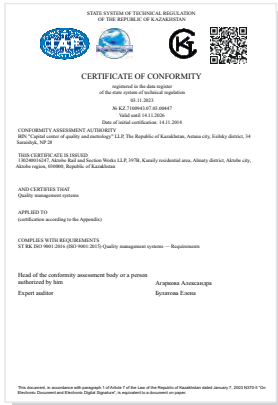

ISO 9001:2015



ISO 45001:2018



ISO 14001:2015

Rails produced by ARBZ have successfully passed the Compliance Certification up to the requirements of TR CU 003/2011 "On the safety of railway transport infrastructure".

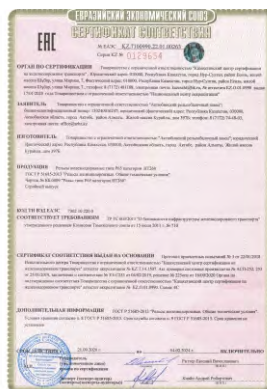
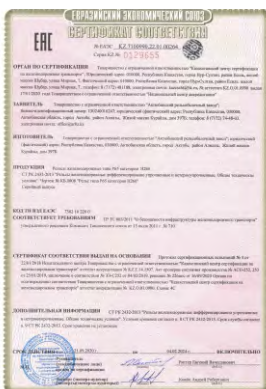
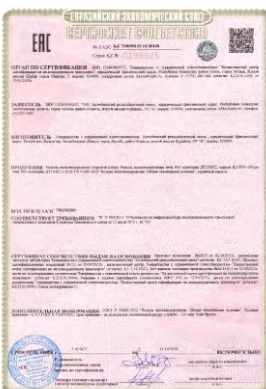
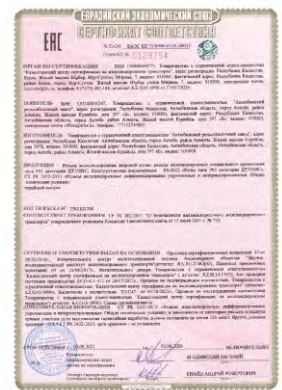
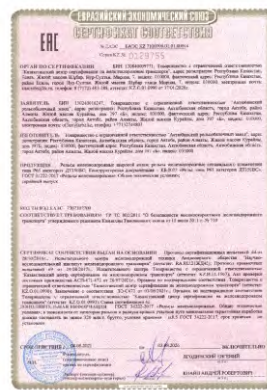
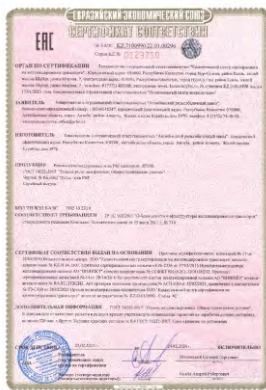

ELECTROENERGY

ARBZ LLP has its own Gas Reciprocating Power Plant (GRPP)

GRPP power is 38,9 MW.

GRPP covers the needs in electrical energy of the works and reduces dependence on external factors.

The equipment is designed in such a way as to prevent accidental contact of personnel with moving, hot or vibrating parts and to minimize the entry of dirt and dust into the environment. The automatic control and monitoring system of GRPP provides safe, reliable, efficient and convenient control of generator sets, their auxiliary mechanical and electrical systems.



ENVIRONMENT

The background of the page is a light blue sky with soft, out-of-focus clouds. Several bright green, multi-lobed leaves are scattered across the frame, primarily in the top right and bottom corners, creating a natural and fresh aesthetic.

Environmental protection is an integral part of the activities of Aktobe Rails and Section Works LLP and its approach to sustainable development management. ARBZ LLP recognizes its responsibility for the impact on the environment, health, safety and quality of life of the population and takes all necessary measures to ensure environmental safety, preserve the natural environment in the location of production activities, rational use of natural resources and minimize environmental impact.

The production meets international requirements and is a green investment in the economy of Kazakhstan.

The Enterprise uses innovative technologies and equipment that eliminates and minimizes unauthorized emissions into the atmospheric air.

The works has organized the first technology of drainless industrial production in Kazakhstan, which allows to reduce water consumption for production by up to 70%, which allows not only to reduce environmental pollution by industrial effluents, but also significantly reduce water consumption for the needs of the plant by 300 thousand m³ of clean water.

PARTNERS AND CLIENTS



REVIEWS



"Based on the operation results, laid rails showed high quality, enhanced characteristics, reliability and wear resistance". For all the time of its operation, ARBZ LLP has established itself as a trusted and responsible partner with professional and qualified staff."

NC Kazakhstan Temir Zholy JSC

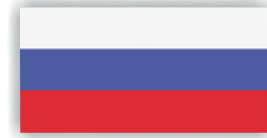

"Strict observance of ARBZ LLP of the Contract terms, that is: dates, delivery terms, product quality, as well as high professionalism of Company's management in terms of arrangement of negotiations, efficiency in work, fulfillment of assumed obligations"

"NIK" JSC administration



"Rails provided by the works meet the GOST requirements to high quality products"

BelZhd administration

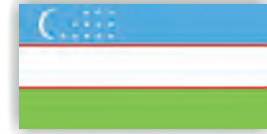

"Rails that we received own stable welding characteristics, sufficient straightness and quality confirmed by lack of defects during the whole period of performance"

Usbekiston temir yullari



"The rails were used during the overhaul of mainline railway tracks and the construction of new railways. We received no claims on the quality from operating companies"

Turkmen demiryollary



"Employees of Your company are sufficiently loyal, able to immediately consult a client and provide a full information about a product. It is also worth mentioning that we were delighted by the soonest delivery date."

the company provides the rails delivery to NC Kyrgyz Temir Zholu

 Building 397 B, Kuraily residential area, Almaty district, Aktobe city, Aktobe region, postal code 030000, Republic of Kazakhstan

 +7 (7132) 74-48-03

 +7 (7132) 74-48-31

 office@arbz.kz



arbz.kz